

Right the First Time Safe, Accurate, Service Friendly



Tank Weighing

SWB505 MultiMount weigh modules offer rugged construction and many features for easy installation and accurate and reliable tank weighing. Standard lift-off screw copes with tipping forces while vertical down stop provides additional safety.



Conveyors and Mixers

SWB505 weigh modules are also designed for dynamic-loading applications such as conveyors, mixers and blenders. SWB505 provides 360° checking for ease of installation and maximum safety. The rocker pin restores the top plate to its ideal position to maintain accurate, repeatable weight.



Load Cell

Analog load cell uses a rocker-pin design that automatically aligns load forces for accurate weighing. The hermetically sealed load cell is rated IP68 and can be used in all environments. The load cell is easy to inspect or replace.



Stabilizers

Up to two optional stabilizers can be applied to each weigh module to stabilize a scale subject to heavy vibration, high torque, or in-motion weighing. With stabilizers installed, thermal expansion is still possible, guaranteeing the best weighing performance.



Right the First Time

SWB505 MultiMount features ensure correct scale system installation, right from the start. MultiMount does not compromise on safety – all safety features are built-in. The rocker pin design provides the highest level of weighing accuracy. Service features, including SafeLock™ provide easy and trouble free installation. SWB505 features:

- Integrated lift-off protection
- Vertical safety down stop
- Full 360° integrated checking
- Ground strap – welding protection
- SafeLock™ – Weigh module locked for installation
- SafeLock™ – Load cell protected for installation
- Dual stabilizer option
- Capacity range: 5kg – 4.4t
- IP68 load cell, hermetically sealed, stainless steel
- Global approvals standard on each load cell
- Zinc plated or stainless steel mounting hardware
- Calibration without testweights

SWB505 MultiMount Specifications – Weigh Module

Weigh Module		unit of measure		Specification												
Model No.		SWB505 Multimount														
Size		1						2						3		
Rated Capacity		kg (lb)	5 (11)	10 (22)	20 (44)	50 (110)	100 (220)	200 (441)	300 (661)	110 (250)	220 (500)	550 (1250)	1100 (2500)	2200 (5000)	4400 (10000)	
Load Limit, safe ⁹⁾	carbon steel	kg (lb)	7.5 (17)	15 (33)	30 (66)	75 (165)	150 (330)	300 (662)	450 (992)	165 (375)	330 (750)	825 (1875)	1650 (3750)	2980 (6700)	5920 (13300)	
	stainless steel	kg (lb)												2350 (5160)	5200 (11700)	
Load Limit, safe ⁹⁾ without load cell		kg (lb)	300 (675)						2200 (5000)						4400 (10000)	
Restoring Force ⁵⁾		%A.L./mm (.../in) ³⁾	7.4 (190)						4.4 (111)						5.5 (140)	
Max. horizontal force	transverse ⁶⁾	kN (lb)	3 (675)						7.5 (1685)						15 (3370)	
	longitudinal ⁶⁾		1.5 (337)						5 (1120)						7.4 (1660)	
Max. horizontal force (longitudinal) per stabilizer option		longitudinal ⁶⁾	1.5 (337)						5 (1120)						7.4 (1660)	
Max. top plate travel	transverse	mm (in)	± 2.5 (0.10)						± 3 (0.12)						± 3.5 (0.14)	
	longitudinal		± 2.5 (0.10)						± 3 (0.12)						± 3.5 (0.14)	
Max. Uplift Force ⁸⁾		kN (lb)	3 (675)						11.1 (2500)						22.2 (5000)	
Weight (including load cell), nominal		kg (lb)	4 (8.8)						6.6 (14.5)						7 (15.4)	15.4 (34)
Material		carbon steel / 304 stainless steel / 316 stainless steel														
Finish		Zinc Plated / Electropolished / Electropolished														

¹⁾ Error due to the combined effect of non-linearity and hysteresis

²⁾ Typical values only. The sum of errors due to Combined Error and Temperature Effect on Sensitivity comply with the requirements of OIML R60 and NIST HB44.

³⁾ A.L. = Applied Load

⁴⁾ See certificate for complete information.

⁵⁾ % of Applied Load (A.L.) per mm (in) displacement of the top plate (transverse & longitudinal).

⁶⁾ Maximum horizontal force that can be applied to top plate.

⁸⁾ Maximum vertical uplift force that can be applied to the top plate.

⁹⁾ Maximum vertical downward force that can be applied to the top plate.

SWB505 MultiMount Specifications – Load Cell

Load Cell		unit of measure		Specification											
Model No.		MTB							0745A						
Rated Capacity (R.C.)	kg (lb)	5 (11)	10 (22)	20 (44)	50 (110)	100 (220)	200 (441)	300 (661)	110 (250)	220 (500)	550 (1250)	1100 (2500)	2200 (5000)	4400 (10000)	
Rated Output	mV/V @R.C.-kg	2 ± 0.002							0.970 ± 0.002	1.940 ± 0.002					
	mV/V @R.C.-lb	n/a							1.000 ± 0.002	2.000 ± 0.002					
Combined Error ^{1) 2)}	%R.C.	≤ 0.018							0.03	≤ 0.018					
Temperature Effect on	Min. Dead load Output	≤ 0.001 (0.0006)							≤ 0.0027 (0.0015)	≤ 0.0020 (0.0010)					
	Sensitivity ²⁾	≤ 0.0009 (0.0005)													
Temperature Range	Compensated	-10 ~ +40 (+14 ~ +104)													
	Operating	-20 ~ +65 (-4 ~ +150)													
	Safe Storage	-40 ~ +80 (-40 ~ +176)													
OIML / European Approval ⁴⁾	Class	C3							–	C3					
	nmax	3000							–	3000					
	Vmin	g (lb)	–	0.8 (0.0018)	1.7 (0.0037)	4.2 (0.009)	8.3 (0.018)	16.7 (0.037)	25 (0.055)	–	32 (0.070)	79 (0.175)	159 (0.35)	317 (0.70)	635 (1.40)
NTEP Approval ⁴⁾	Class	IIIS / III M							–	III M					
	nmax	3000 / 5000							–	5000					
	Vmin	g (lb)	0.4 (0.0009)	0.8 (0.0018)	1.7 (0.0037)	4.2 (0.009)	8.3 (0.018)	16.7 (0.037)	25 (0.055)	–	32 (0.070)	79 (0.175)	159 (0.35)	317 (0.70)	635 (1.40)
ATEX Approval ⁴⁾	Rating	II 2 G Ex ib IIC T4							II 2 G Ex ia IIC T4						
		II 2 D Ex ibD 21 IP6X T135°C							II 2 D Ex tD A21 IP6X T100°C						
		II 3 G Ex nA II T4							II 3 G Ex nA II T4						
		II 3 G Ex nL IIC T4							II 3 G Ex nL IIC T4						
		II 3 D Ex tD A22 IP6X T135°C							II 3 D Ex tD A22 IP6X T100°C						
Entity Parameters		Ui=25V, Ii=600mA, Pi=1.25W, Ci=0.2nF/m, Li=1.0µH/m							Ui/Un=25V, Ii=600mA, Pi=1.25W, Ci=5nF, Li=30µH						
Number		3005885													
Number, Canada		3025753C													
Factory Mutual Approval ⁴⁾	Rating	IS / I,II,III / 1 / ABCDEFG / T4							IS / I,II,III / 1 / ABCDEFG / T4						
		NI / 1 / 2 / ABCD / T6							NI / 1 / 2 / ABCD / T6						
		S / II,III / 2 / FG / T6							S / II,III / 2 / FG / T6						
Entity Parameters		Vmax=25V, Imax=600mA, Pi=1.25W, Ci=0, Li=0							Vmax=25V, Imax=600mA, Pi=1.25W, Ci=0, Li=29µH						
System Drawing No, USA		72184367							158574R						
System Drawing No, Canada		72189337							158574R, 42111392						
Excitation Voltage	Recommended	5–15													
	Max.	20													
Terminal Resistance	Excitation	≥ 383							≥ 385						
	Output	350 ± 1							350 ± 2						
Material	Spring Element	stainless steel													
	Type	welded													
Protection	IP Rating	IP 68													
	NEMA Rating	NEMA 6/6P													
Load Limit	Safe	150													
	Ultimate	300													
Deflection @ R.C., nominal	mm (in)	0.30 (0.012)	0.40 (0.016)			0.50 (0.020)	0.75 (0.030)	0.07 (0.003)	0.14 (0.005)	0.23 (0.009)	0.34 (0.013)	0.52 (0.020)	0.62 (0.024)		
Weight, nominal	kg (lb)	0.6 (1.3)							0.9 (2)			1.3 (2.9)	2 (4.4)		
Cable Length	m (ft)	3, 5 (9.8, 16.6)							2.2, 4.5, 9.1, 18.2 (7.5, 15, 30, 60)						



SWB505 Weigh Module Dimensions mm [inch]

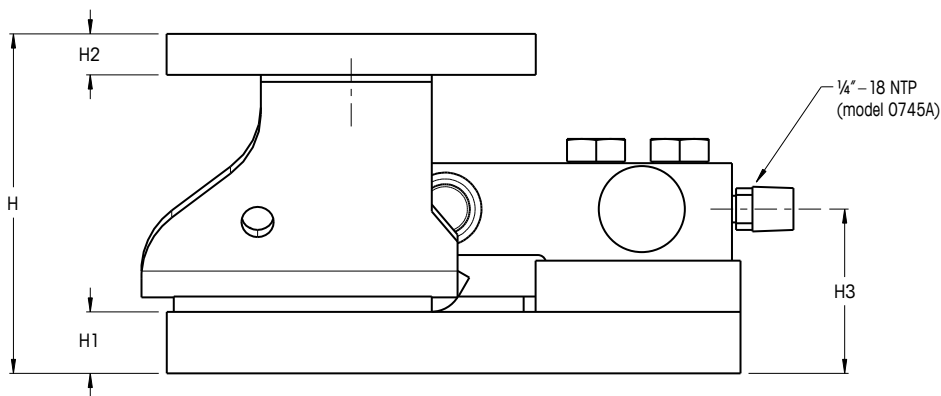
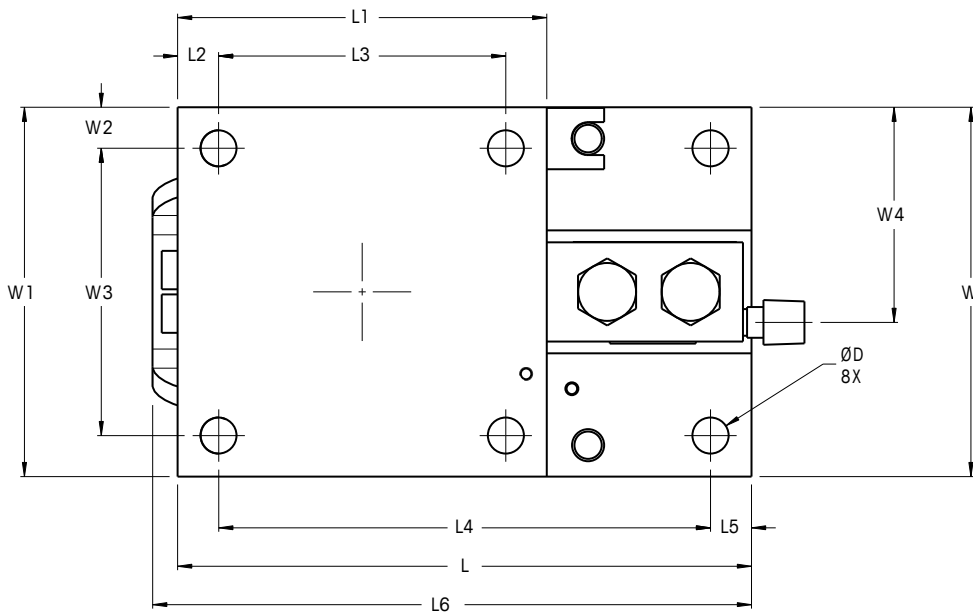

Size	Capacity	Locations and Dimensions																
		D	H	H1	H2	H3	L	L1	L2	L3	L4	L5	L6	W	W1	W2	W3	W4
1	5 kg – 300kg (11 lb – 600lb)	10 (0.4)	83 (3.3)	12.7 (0.50)	8 (0.3)	41.0 (1.61)	165 (6.5)	102 (4.0)	10 (0.4)	82 (3.2)	145 (5.7)	10 (0.4)	-	102 (4.0)	102 (4.0)	10 (0.4)	82 (3.3)	60.0 (2.36)
2	110kg – 1.1t (250lb – 2.5klb)	11.2 (0.44)	105.2 (4.14)	19.1 (0.75)	12.7 (0.50)	50.9 (2.00)	177.9 (7.00)	114.4 (4.50)	12.7 (0.50)	89.0 (3.5)	152.4 (6.00)	12.7 (0.50)	185.6 (7.31)	114.4 (4.50)	114.4 (4.50)	12.7 (0.50)	89.0 (3.5)	66.6 (2.62)
	51.3 (2.02)					69.7 (2.74)												
3	4.4t (10klb)	17.5 (0.69)	136.6 (5.38)	25.4 (1.00)	19.1 (0.75)	70.3 (2.77)	235.0 (9.25)	152.4 (6.00)	25.4 (1.00)	101.6 (4.00)	184.2 (7.25)	25.4 (1.00)	-	152.4 (6.00)	152.4 (6.00)	25.4 (1.00)	101.6 (4.00)	91.7 (3.61)

SWB505 Weigh Module Arrangements²

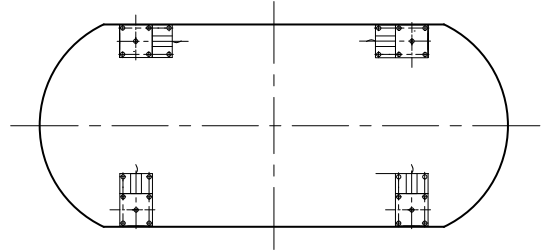
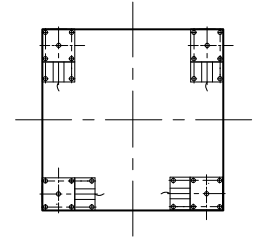
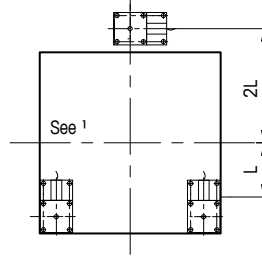
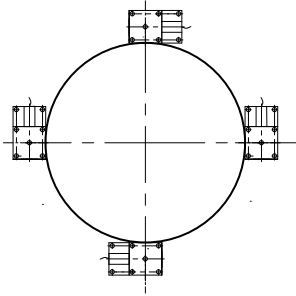
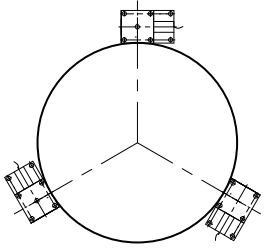

¹ provide equal distribution, but the stability of this arrangement must be assured

² Weigh modules may be orientated as desired only if stabilizers will not be used

Order Information SWB505 – Weigh Module including Load Cell

Weigh Module Assembly SWB505 (including analog load cell MTB) Size 1	Zinc Plated	304 Stainless steel	316 Stainless steel**
Weigh Module Assembly SWB505 Size 1, 5kg 0.05% - 3m	30040372	30040863	30040920
Weigh Module Assembly SWB505 Size 1, 10kg C3/III M n:5 -3m	30040373	30040864	30040921
Weigh Module Assembly SWB505 Size 1, 20kg C3/III M n:5 -3m	30040374	30040865	30040922
Weigh Module Assembly SWB505 Size 1, 50kg C3/III M n:5 -3m	30040375	30040866	30040923
Weigh Module Assembly SWB505 Size 1, 100kg C3/III M n:5 -3m	30040376	30040867	30040924
Weigh Module Assembly SWB505 Size 1, 200kg C3/III M n:5 -3m	30040861	30040868	30040925
Weigh Module Assembly SWB505 Size 1, 300kg C3/III M n:5 -3m	30040862	30040869	30040926

Options SWB505 Size 1

Stabilizer Size 1*, 5kg – 300kg	–	30040930	30040931
Dead Stand Size 1, 5kg – 300kg	–	30025909	30025913
Shock/Vibration Pad Size 1, 5kg – 300kg		30040932	
Thermal Isolation Pad 80°C Size 1, 5kg – 300kg		30040933	
Thermal Isolation Pad 170°C Size 1, 5kg – 300kg		30040935	

Weigh Module Assembly SWB505 (including analog load cell 0745) Size 2	Zinc Plated	304 Stainless steel	316 Stainless steel**
Weigh Module Assembly SWB505 Size 2, 110kg/250lb 0.03% -4.5m (15ft)	61043206	61043215	61046391
Weigh Module Assembly SWB505 Size 2, 220kg/500lb C3/III M n:5 -4.5m (15ft)	61043207	61043216	61046392
Weigh Module Assembly SWB505 Size 2, 550kg/1250lb C3/III M n:5 -4.5m (15ft)	61043208	61043217	61046393
Weigh Module Assembly SWB505 Size 2, 1100kg/2500lb C3/III M n:5 -4.5m (15ft)	61043209	61043218	61046394
Weigh Module Assembly SWB505 Size 2, 2200kg/5000lb C3/III M n:5 -4.5m (15ft)	61043210	61043219	61046395

Options SWB505 Size 2

Stabilizer Size 2*, 110–2200 kg (250–5000 lb)	61046399	61046400	61046401
Dead Stand Size 2, 110–2200 kg (250–5000 lb)	61010624	61046402	61046403
Shock/Vibration Pad Size 2, 110–2200 kg (250–5000 lb)		61005965	
Thermal Isolation Pad 80°C Size 2, 110–2200 kg (250–5000 lb)		61010620	
Thermal Isolation Pad 170°C Size 2, 110–2200 kg (250–5000 lb)		61024642	
Adapter Conduit	61005937	61010683	–

Weigh Module Assembly SWB505 (including analog load cell 0745) Size 3**	Zinc Plated	304 Stainless steel	316 Stainless steel**
Weigh Module Assembly SWB505 Size 3**, 4400kg/10000lb C3/III M n:5 -9.1m (30ft)	61043211	61043220	61046396

Options SWB505 Size 3**

Stabilizer Size 3*, 4400kg/10000lb	61046404	61046405	61046406
Dead Stand Size 3, 4400kg/10000lb	61010625	61046407	61046408
Shock/Vibration Pad Size 3, 4400kg/10000lb		61005938	
Thermal Isolation Pad 80°C Size 3, 4400kg/10000lb		61010621	
Thermal Isolation Pad 170°C Size 3, 4400kg/10000lb		61037510	
Adapter Conduit	61005937	61010683	–

Bolded entries are stocked

* 1 or 2 per weigh module.

** 06/2013

Order Information SWB505 – Weigh Module without Load Cell

- SafeLock™ allows to install weigh module hardware without load cell to avoid sensor damage
- Combine weigh module with special cable length and cable material
- Use weigh module with dummy load cell for level detection systems

Weigh Module Kit SWB505 (without load cell) Size 1	Zinc Plated	304 Stain- less steel	316 Stain- less steel**	Suitable Load Cells MTB	
Weigh Module Kit SWB505 Size 1 5kg – 300kg	30040927	30040928	30040929	5kg -3m 71209934	5kg -5m 72208033
				10kg C3/III M n:5 -3m 71209642	10kg C3/III M n:5 -5m 72208034
				20kg C3/III M n:5 -3m 71201556	20kg C3/III M n:5 -5m 72208035
				50kg C3/III M n:5 -3m 71201557	50kg C3/III M n:5 -5m 72208036
				100kg C3/III M n:5 -3m 71201558	100kg C3/III M n:5 -5m 72208037
				200kg C3/III M n:5 -3m 71201559	200kg C3/III M n:5 -5m 72208038
				300kg C3/III M n:5 -3m 71201560	300kg C3/III M n:5 -5m 72208039
				Dummy Load Cell MTB 30025910	

Weigh Module Kit SWB505 (without load cell) Size 2	Zinc Plated	304 Stain- less steel	316 Stain- less steel**	Suitable Load Cells 0745A				Suitable Load Cells 0745A – FEP cable		
Weigh Module Kit SWB505 Size 2 110kg/220lb – 1100kg/2500lb	61043213	61043222	61046397	110kg -2.2m 72233956	110kg -4.5m 72233957	110kg -9.1m 72233958		110kg -2.2m FEP 72233959	110kg -4.5m FEP 72233960	
				220kg -2.2m 64052903	220kg -4.5m 64052904	220kg -9.1m 64052905		220kg -2.2m FEP 64052906	220kg -4.5m FEP 64052907	
				550kg -2.2m 64052908	550kg -4.5m 64052909	550kg -9.1m 64052910	550kg -18.2m 64052911	550kg -2.2m FEP 64052912	550kg -4.5m FEP 64052913	550kg -9.1m FEP 64052914
				1100kg -2.2m 64052915	1100kg -4.5m 64052916	1100kg -9.1m 64052917	1100kg -18.2m 64052918	1100kg -2.2m FEP 64052919	1100kg -4.5m FEP 64052920	1100kg -9.1m FEP 64052921
				Dummy Load Cell 0745 110kg – 1100kg 68000714						
Weigh Module Kit SWB505 Size 2 2200kg/5000lb	61046636	61046637	61046638	2200kg -2.2m 64052922	2200kg -4.5m 64052924	2200kg -9.1m 64052925	2200kg -9.1m 64052925	2200kg -2.2m FEP 64052927	2200kg -4.5m FEP 64052928	2200kg -9.1m FEP 64052929
Dummy Load Cell 0745 2200kg 61005963										

Weigh Module Kit SWB505 (without load cell) Size 3**	Zinc Plated	304 Stain- less steel	316 Stain- less steel**	Suitable Load Cells 0745A				Suitable Load Cells 0745A – FEP cable		
Weigh Module Kit SWB505 Size 3** 4400kg/10000lb	61043214	61043223	61046398	–	4400kg -4.5m 64052930	4400kg -9.1m 64052931	4400kg -18.2m 64052932	–	4400kg -4.5m FEP 64052933	4400kg -9.1m FEP 64052934
Dummy Load Cell 0745 4400kg 61005964										

Bolded entries are stocked
** 06/2013

SWB505 Cable Colors MTB

Colour	Function
Green	+ Excitation
Black	- Excitation
White	+ Signal
Red	- Signal
Yellow	+ Sense
Blue	- Sense
Yellow	Shield

SWB505 Cable Colors 0745A

Colour	Function
Green	+ Excitation
Black	- Excitation
White	+ Signal
Red	- Signal
Yellow	Shield

Full Connectivity

METTLER TOLEDO supplies various data communication interfaces that enable our sensors and instruments to communicate with your PLC, MES, or ERP systems.



METTLER TOLEDO Service

Our extensive service network is among the best in the world and ensures maximum availability and service life of your product.

Weighing Electronics

METTLER TOLEDO offers a complete family of electronics from simple weighing to application solutions for filling, stock control, batching, formulation, counting, and checkweighing.



Quality certificate ISO 9001
Environment certificate ISO 14001

Subject to technical changes.
© 01/2013 Mettler-Toledo AG
Printed in Switzerland MTSI 44098436
MarCom Industrial

www.mt.com

Visit for more information